



NETBOX MEB

■ Product Description

NETBOX MEB is a built-in power, data and multimedia unit particularly for shop fittings.

■ Product Specification

- Comes in 2, 3 or 4 gang configuration
- Customisable into various configurations
- Sleek and attractive design
- Comes with built in starter cable
- Plug & Play technology

■ Application Range

- Training Tables
- Workstations
- Panel Systems

■ Technical Details

- Rated for 110V to 250V and a maximum of 20A according to country specific standards
- Low concentration of heavy metal
- Material: PA-FR (self-extinguishing according to UL94)
- Wiring: 3 x 1.5mm² standard; 3 x 2.5mm² upon request

Please follow local standards for electrical installation.



A. & H. Meyer GmbH
Leuchten und Büroelektrik

Fermke 8
32694 Dörentrup
Germany

T: +49 5265 9488 0
F: +49 5265 9488 11
www.ah-meyer.de

A. & H. Meyer Sdn Bhd
(528797-M)
No. 3, Jalan Astaka U8/84
Section U8, Bukit Jelutong
40150 Shah Alam, Selangor
Malaysia

T: +603 7845 7277
F: +603 7845 2155
sales@ah-meyer.com.my

Dimensions

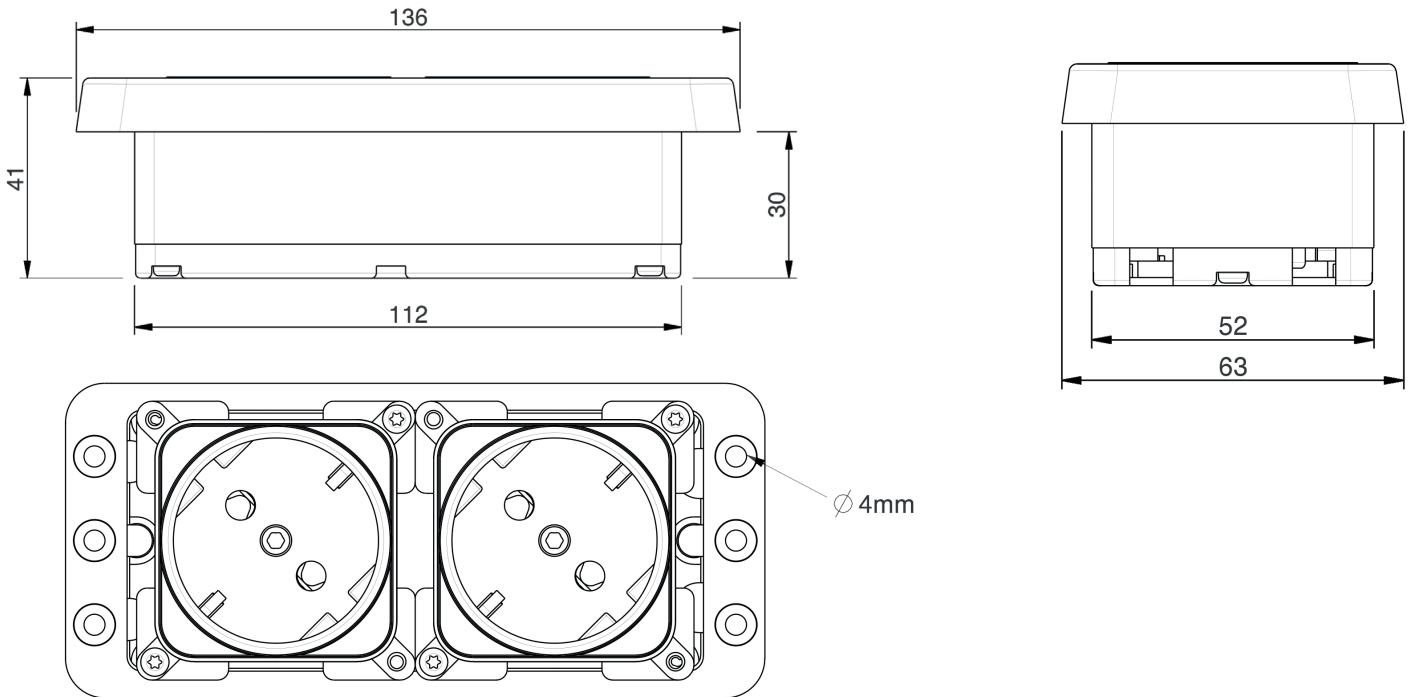

Cut Out

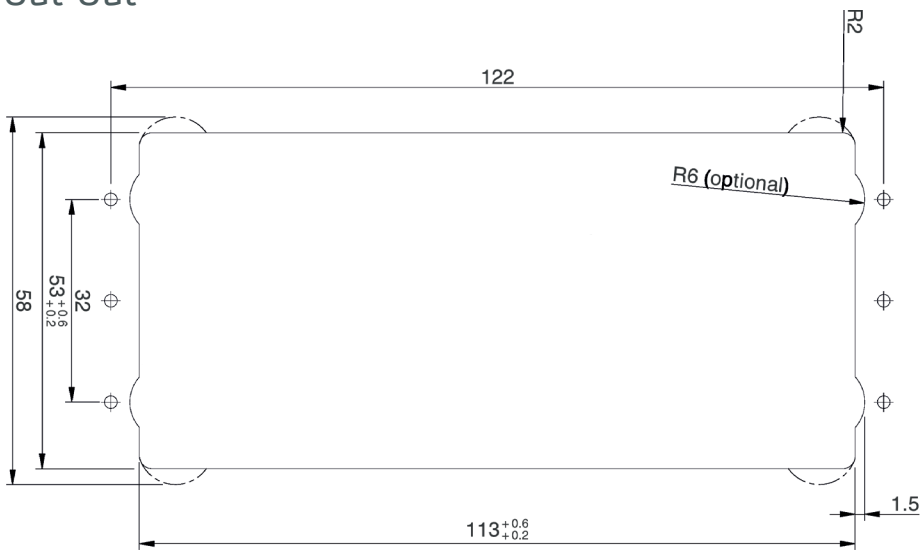

Standards and Approvals

Country	Malaysia	Singapore Hong Kong	India	China	Australia New Zealand	Japan	GCC Countries	Korea
Approvals / Test Institute								

Dimensions

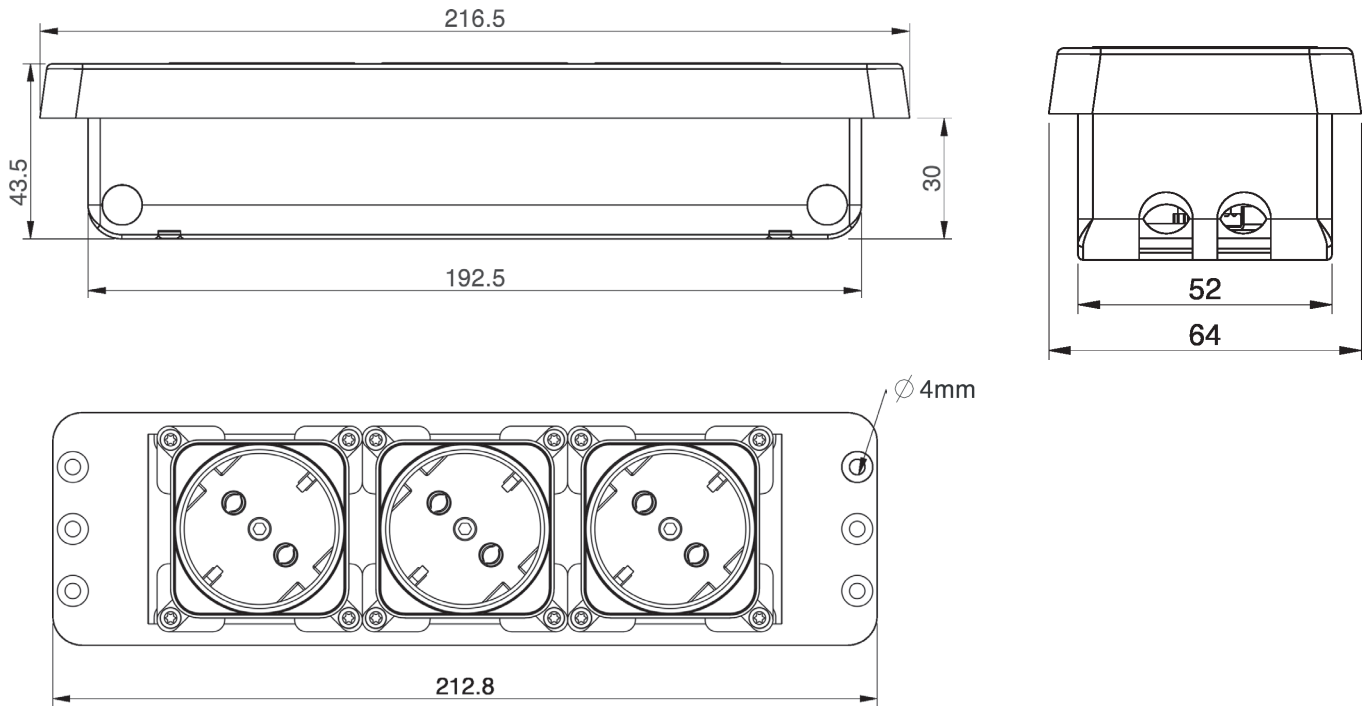

Cut Out

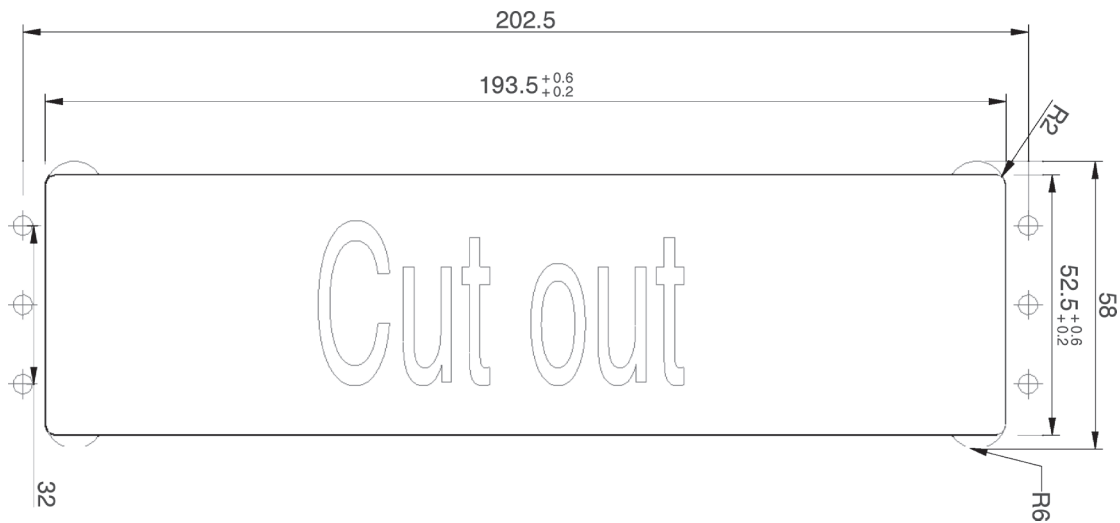

Standards and Approvals

Country	Malaysia	Singapore Hong Kong	India	China	Australia New Zealand	Japan	GCC Countries	Korea
Approvals / Test Institute								

Dimensions

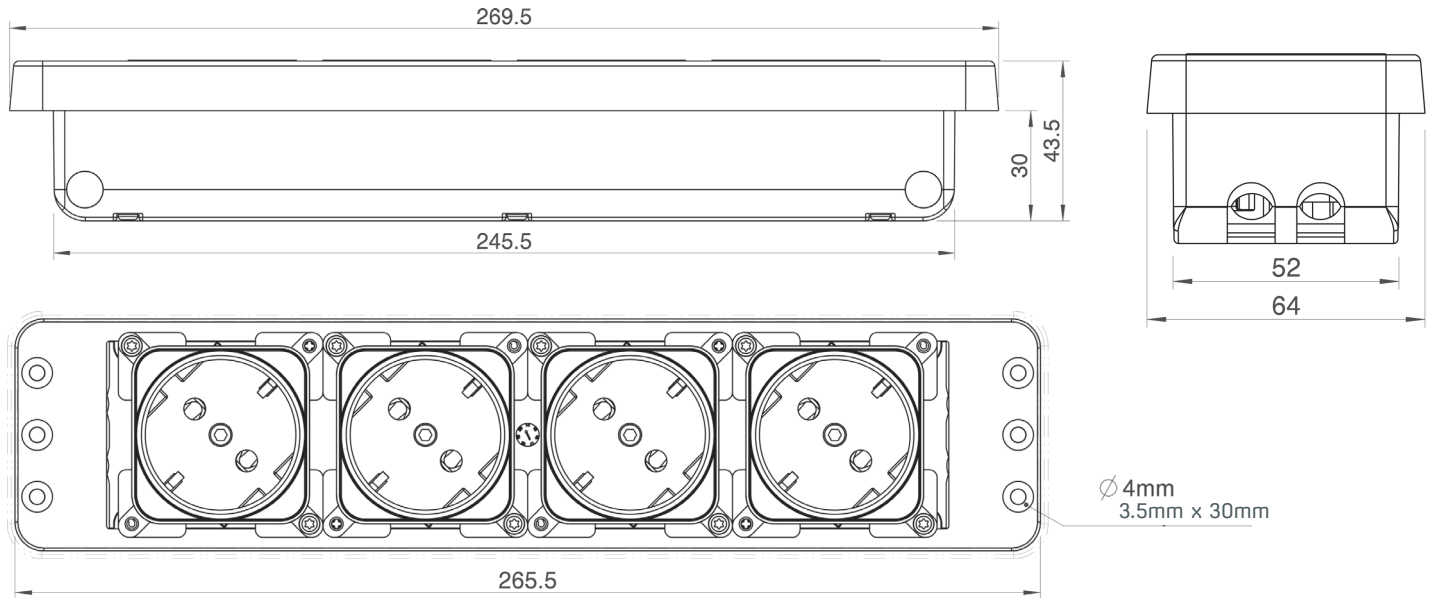

Cut Out

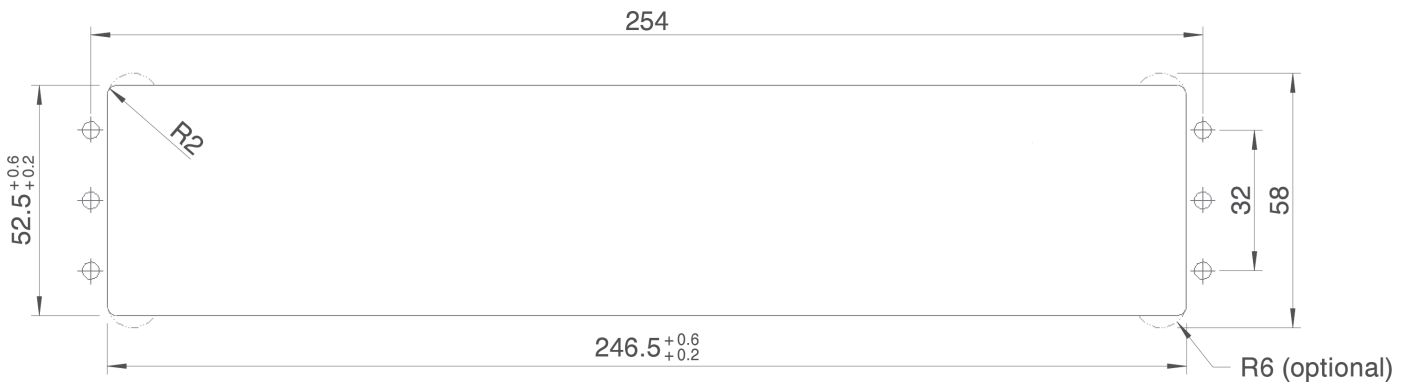

Standards and Approvals

Country	Malaysia	Singapore Hong Kong	India	China	Australia New Zealand	Japan	GCC Countries	Korea
Approvals / Test Institute								