



NETBOX M2

■ Product Description

NETBOX M2 is a standard power, data and multimedia unit in plastic finish which comes fitted with detachable frame.

■ Product Specification

- Functional and cost efficient
- Standard model for power, voice and data transmission
- Several NETBOX M can be interconnected using connector cables
- Can be installed and mounted on any given surface or concealed within partitions and cable trays
- Plug & Play technology

■ Application Range

- Workstations
- Cable Trays
- Panel Systems
- Home Office

■ Technical Details

- Rated for 110 to 250V, and up to a maximum of 20A
- Material: ABS-FR
- Wiring: 3 x 1.5mm² standard; 3 x 2.5mm² upon request

Please follow local standards for electrical installation.

A. & H. Meyer GmbH
Leuchten und Büroelektrik

Fermke 8
32694 Dörentrup
Germany

T: +49 5265 9488 0
F: +49 5265 9488 11
www.ah-meyer.de

A. & H. Meyer Sdn Bhd
(528797-M)
No. 3, Jalan Astaka U8/84
Section U8, Bukit Jelutong
40150 Shah Alam, Selangor
Malaysia

T: +603 7845 7277
F: +603 7845 2155
sales@ah-meyer.com.my

Dimensions

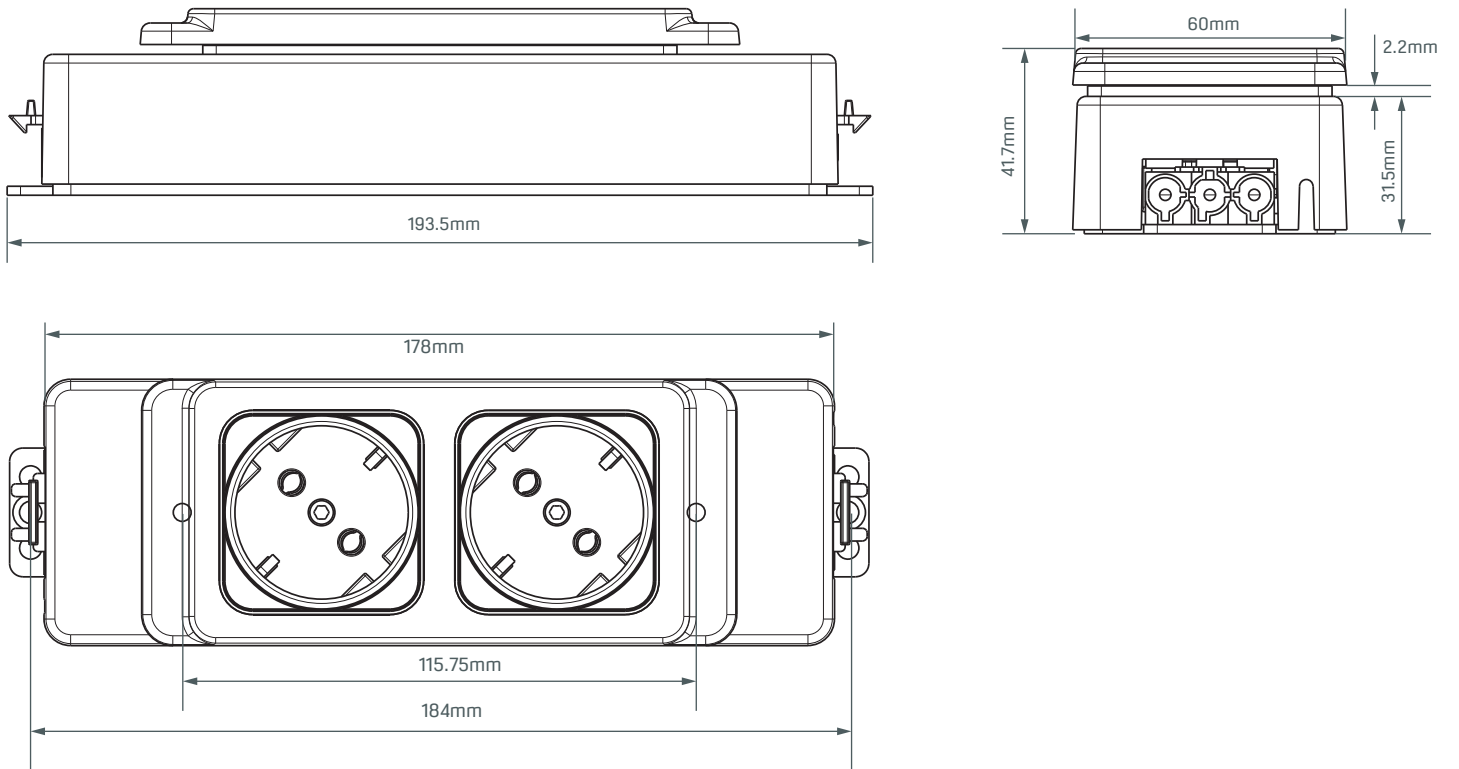

Cut Out

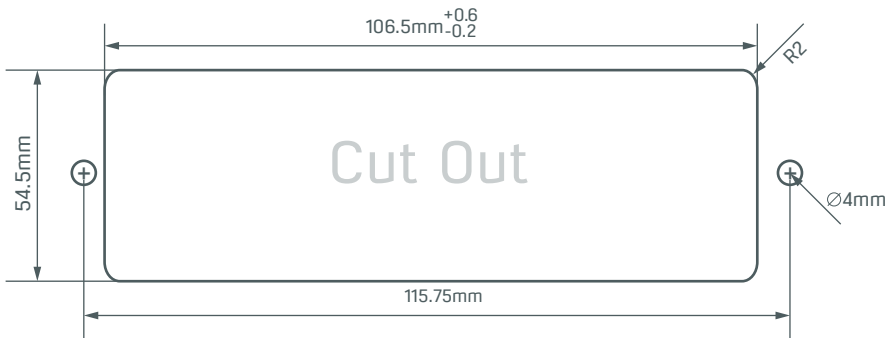

Standards and Approvals

Country	Malaysia	Singapore Hong Kong	India	China	Australia New Zealand	Japan	GCC Countries	Indonesia	Korea
Approvals / Test Institute									