



NETBOX Rail+

■ Product Description

NETBOX Rail+ is a built in power, data and multimedia unit in aluminum finish for thin panel systems.

■ Product Specification

- Sleek contemporary profile with aluminum finish
- Suitable for surface mounting on panels and partitions
- Customisable unit with various configurations
- Unit available in any length
- Plug & Play technology
- Low installation depth of 40mm
- Max plate thickness of 35mm

■ Application Range

- Collaborative Areas
- Panel Systems
- Shelf Systems

■ Technical Details

- Rated for 110V to 250V and a maximum of 20A according to country specific standards
- Low concentration of heavy metal
- Aluminum casing is safely grounded against hazardous electrical shock
- Material: PA-FR (self-extinguishing according to UL94)
- Wiring: 3 x 1.5mm² standard; 3 x 2.5mm² upon request

Please follow local standards for electrical installation.



A. & H. Meyer GmbH
Leuchten und Büroelektrik

Fermke 8
32694 Dörentrup
Germany

T: +49 5265 9488 0
F: +49 5265 9488 11
www.ah-meyer.de

A. & H. Meyer Sdn Bhd
(528797-M)
No. 3, Jalan Astaka U8/84
Section U8, Bukit Jelutong
40150 Shah Alam, Selangor
Malaysia

T: +603 7845 7277
F: +603 7845 2155
sales@ah-meyer.com.my

Dimensions

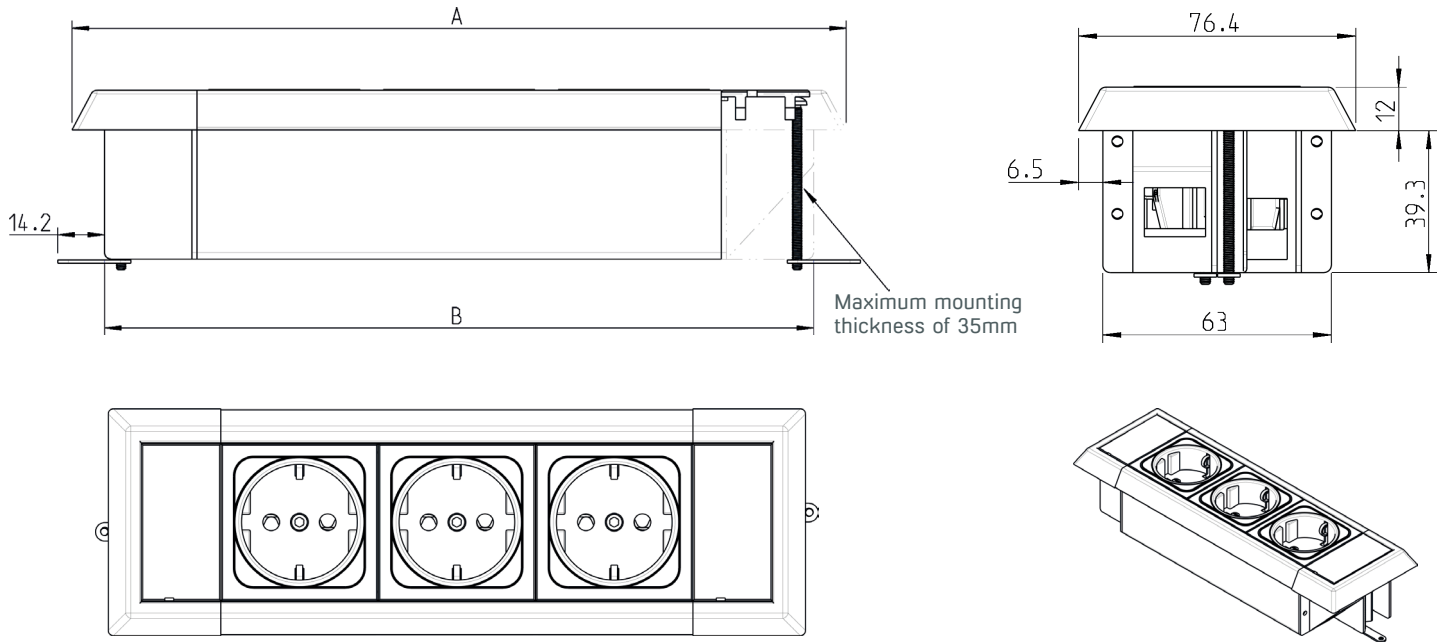

Cut-Out

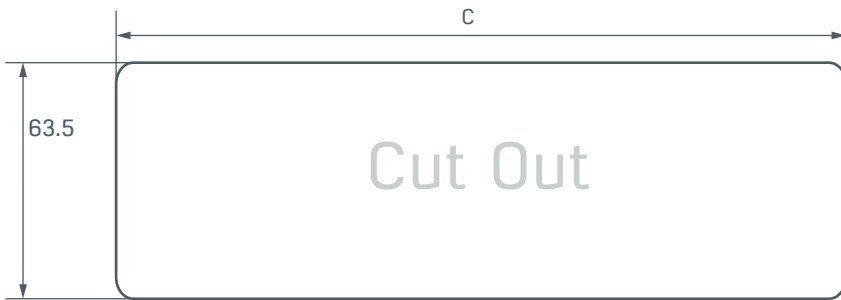

M	2	3	4	5	6	7	8	9	10
A	181.8	234.8	287.8	340.8	393.8	446.8	499.8	552.8	605.8
B	162	215	268	321	374	427	480	533	586
C	162.5	215.5	268.5	321.5	374.5	427.5	480.5	533.5	586.5

M = Number of modules
 A = Total Length
 B = Installation Length
 C = Length of Cut Out

Standards and Approvals

Country	Malaysia	Singapore Hong Kong	India	China	Australia New Zealand	Japan	GCC Countries	Indonesia	Korea
Approvals / Test Institute									